

APPENDIX B - GENERAL BATTERY INFORMATION

When ordering radio batteries, round the order to the next full STANDARD PACK. (See Standard Pack entry in the Radio and Equipment Kit Battery Matrix or see listing in the GENERAL SECTION of the NFES Catalog, under Battery, Radio.)

All NIICD radios utilize alkaline technology batteries. Alkaline batteries should have a shelf life of two years with only about 10% degradation in power. The batteries used in NIICD equipment and applications can probably be stored for four years, however the life will be noticeably shorter.

Battery life with the clamshell-type battery holder will depend upon the AA cells installed, type of radio used, whether the radio is in "scan" mode, and the power output setting on the radio. P25 radios drain batteries more quickly than analog radios.

(See Radio and Equipment Battery Matrix)

Equipment Battery Testing:

Using a voltmeter to determine the state of an SLA battery can yield very inconsistent results. A battery that no longer works on a repeater and which has not had a load placed on it for a few days may read "good" on a voltmeter (a voltmeter does not apply the proper current load). To correctly test the batteries in a repeater with a voltmeter, put the repeater in transmit condition to apply a load to the batteries. **(See Figure 1)**

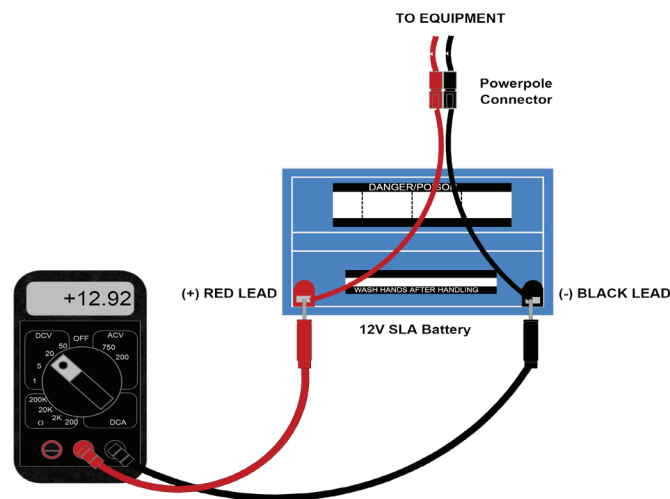

Figure 1: Sample Voltmeter Test on Standalone SLA Battery Configuration

Repeaters: Replace batteries if the voltage is at 10.5 volts with the transmitter keyed up. Starting voltage is about 14 volts with the transmitter operating. Repeater batteries should last 5-7 days under heavy usage.

(See Radio and Equipment Battery Matrix)

Note:

NIICD recommends testing the polarity of each battery before installation.

Some batteries have been known to come labeled incorrectly from the manufacture.

Radios: The transmit LED is the best indicator of battery life. If the light holds bright for 3 seconds while transmitting on high power, the battery should be in good shape. Don't rely on the battery gauge on any radio since they are designed for use with rechargeable batteries. Radio batteries should easily last a shift (usually 12 hours).

(See Radio and Equipment Battery Matrix)

Note:

Alkaline batteries are not considered hazardous waste, except in California. These batteries should be disposed of at the incident to save on shipping costs.

Return all SLA battery kits to NIICD. Ensure battery terminals are covered during transportation. Keep all foreign items out of the kit such as tools and stakes. Do not transport if the 4150 pelican case foam is damaged or missing.

(See SLA 4150 Transportation Instructions)

APPENDIX B - GENERAL EQUIPMENT BATTERY TESTING

System Monitor Battery Testing

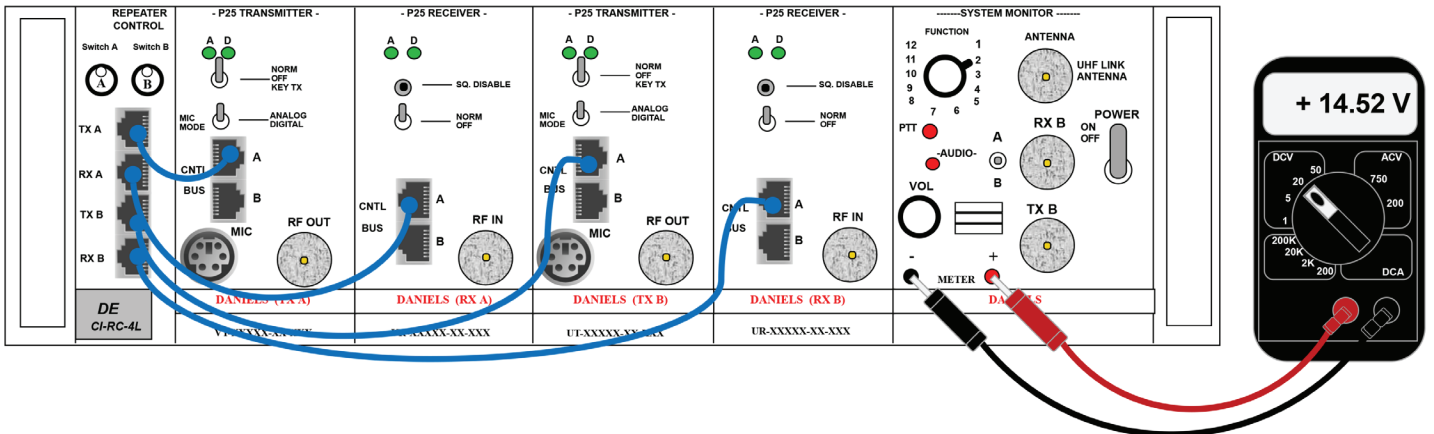

Testing the Equipment Batteries under load on equipment with a System Monitor

- Connect the SLA batteries or Solar Panel Kit to the equipment.
Note: If new batteries are being installed, test each battery voltage and connect accordingly by following the battery diagrams for each piece of equipment.
- Assure that **all power switches** on each module are turned to the "NORM" position.
- Connect a Volt Meter to the Meter Jacks on the **System Monitor Module**.
- Adjust the **Function Switch** on the **System Monitor** to **position 2**.
- Press the "PTT" button on the **System Monitor** to key up the Transmitters to test the battery voltage under a load condition.
- Replace the batteries if the voltage is at or falls below **+10.5 volts** while under load.

System Monitor Switch Functions	
2	+13.8 V (Supply Voltage)
3	+9.5 V Regulated
1, 4-12	NIICD Testing

Note: The equipment voltage can also be tested on the System Monitor equipment by utilizing the Voice Board. See Voice Board Instructions

System Regulator Battery Testing

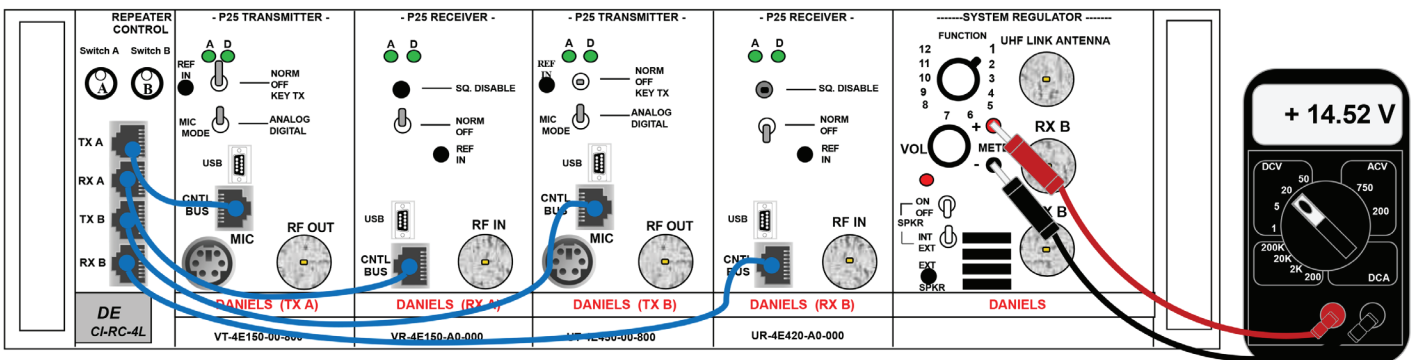

Testing the Equipment Batteries under load on equipment with a System Regulator

- Connect the SLA batteries or Solar Panel Kit to the equipment.
Note: If new batteries are being installed, test each battery voltage and connect accordingly by following the battery diagrams for each piece of equipment.
- Assure that **all power switches** on each module are turned to the "NORM" position.
- Connect a Volt Meter to the Meter Jacks on the **System Regulator Module**.
- Adjust the **Function Switch** on the **System Regulator** to **position 1**.
- Key up the Transmitters by either using a **VHF** or **UHF** handheld to test the battery voltage under a load condition.
- Replace the batteries if the voltage is at or falls below **+10.5 volts** while under load.

System Regulator Switch Functions	
1	+13.8 V (Supply Voltage)
2	+9.5 V Regulated
3-12	NIICD Testing

Note: The equipment voltage can also be tested on the System Regulator equipment by utilizing the Voice Board. See Voice Board Instructions

APPENDIX B - GENERAL EQUIPMENT BATTERY TESTING

Utility Module Battery Testing

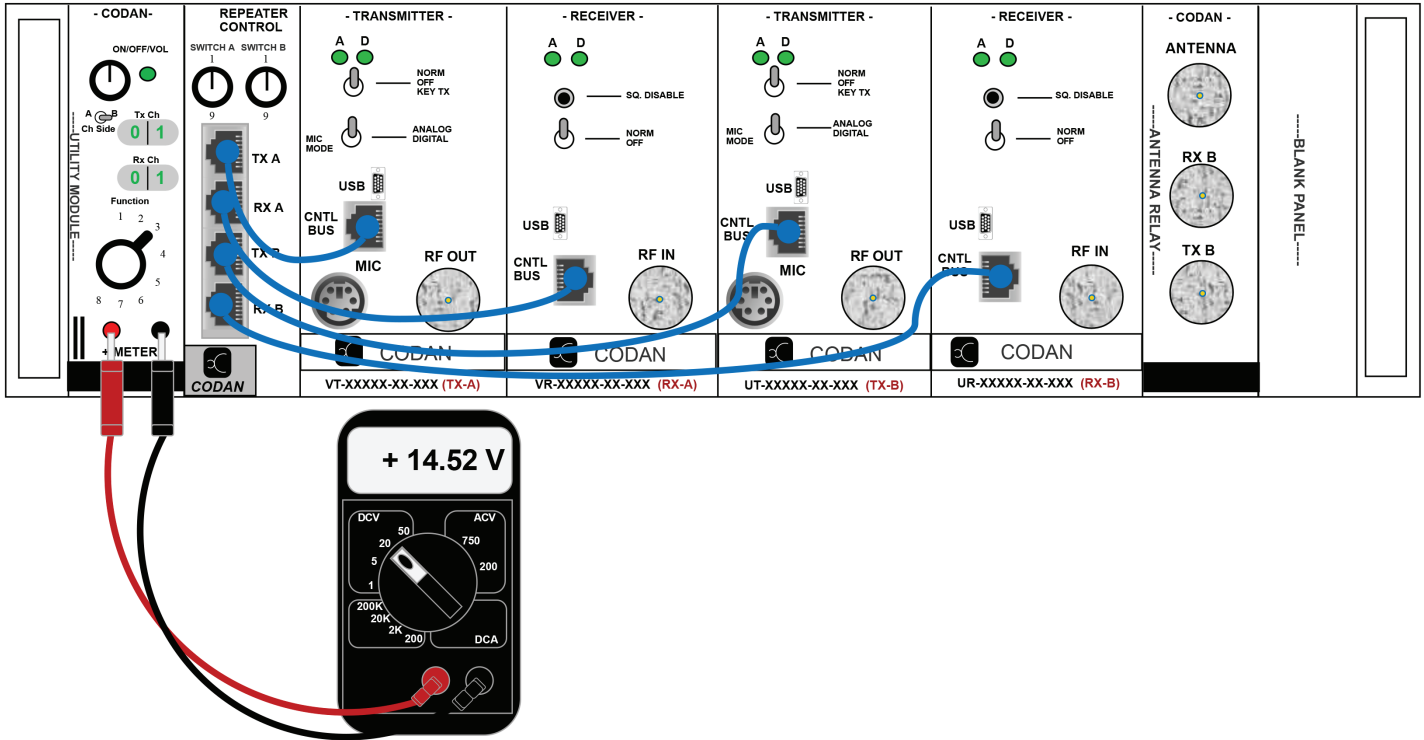

Testing the Equipment Batteries under load on equipment with a Utility Module

- Connect the SLA batteries or Solar Panel Kit to the equipment.
Note: If new batteries are being installed, test each battery voltage and connect accordingly by following the battery diagrams for each piece of equipment.
- Assure that **all power switches** on each module are turned to the "NORM" position.
- Connect a Volt Meter to the Meter Jacks on the **Utility Module**.
- Adjust the **Function Switch** on the **Utility Module** to **position 1**.
- Key up the Transmitters by either using a **VHF** or **UHF** handheld to test the battery voltage under a load condition.
- Replace the batteries if the voltage is at or falls below **+10.5 volts** while under load.

Note: The equipment voltage can also be tested on the Utility Module equipment by utilizing the Voice Board. See Voice Board Instructions

Utility Module Switch Functions	
1	+13.8 V (Supply Voltage)
2	+9.5 V Regulated
3-12	NIICD Testing

APPENDIX B - SLA BATTERY CONFIGURATIONS

In situations when there is heavy voice traffic on the system or where access to the site is limited, NIICD recommends a double-battery system to avoid power failure during the incident. Even with a double battery system, voltage should be checked or batteries replaced every 5-7 days. **(See Figure 2)**

Solar Panel Kits (NFES# 004080) are available from NIICD and are recommended for use at sites with limited access. Contact the CDO for Solar Panel Kit availability before ordering.

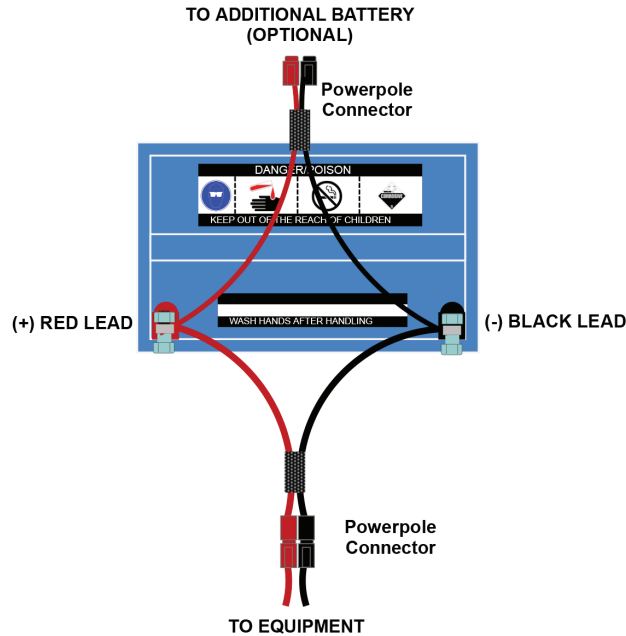

Figure 1:
+12 Volt Single SLA Battery Configuration

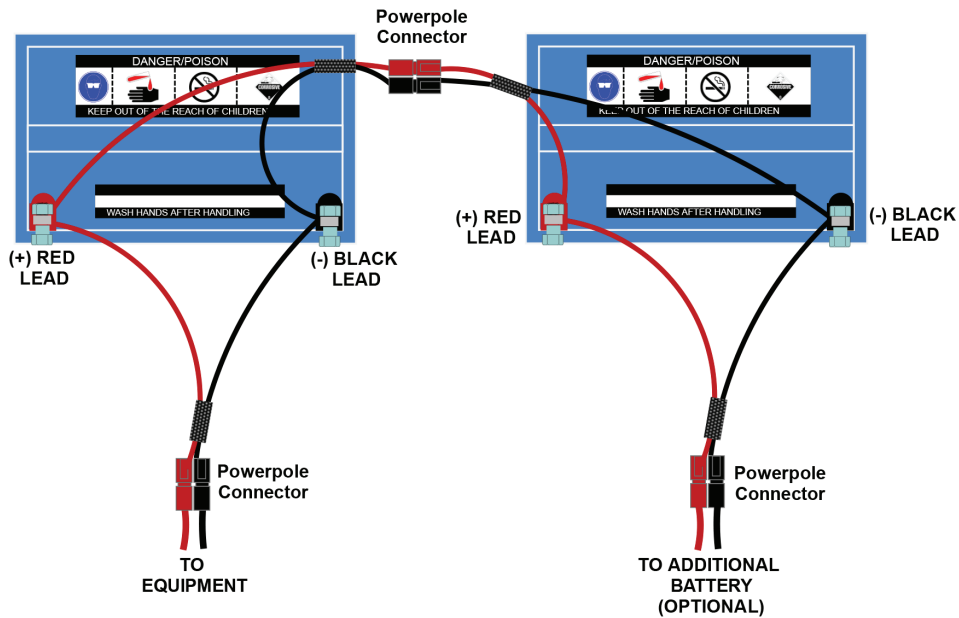

Figure 2:
+12 Volt Single SLA Battery Parallel Configuration

APPENDIX B - 4312, 4248 and 4370 SLA BATTERY INSTALLATION

All 4312, 4248, 4330, 4370 and 4248 kits will be sent from NIICD without any batteries physically connected to the equipment. The user must install the batteries from the NFES# 4150 SLA Battery Kit or NFES# 4080 Solar Panel Kit to make them operational. Please following the appropriate battery configuration and installation procedure for each piece of equipment.

1. 4150 SLA Kit Supplied Materials

- 1 each 4150 - SLA Battery Kit
- 2 each 35 AMP-HR SLA Battery
- 2 each Pre-Wired and connected Power-Pole Y-Cables

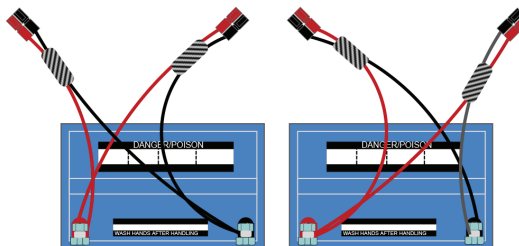

2. Configuring the batteries (See SLA Battery Configuration)

- Ensure both batteries are fully charged
- Place both SLA batteries inside the kit as shown
- Configure the SLA batteries in parallel with pre-assembled Power-Pole cable assembly
- Connect one end of the Power-Pole cable assembly to Equipment Power-Pole cable assembly.

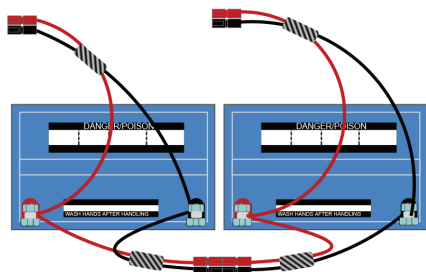

12 Volt SLA Battery Configuration in Parallel

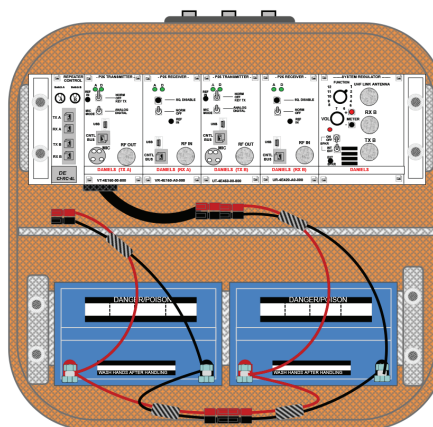

Equipment Kit Enclosure
12 Volt SLA Battery Configuration

3. Battery Protection (See Equipment Kit Enclosure)

Cover the terminals with supplied cover to prevent accidental short circuits.

Note: Always remove the batteries from each kit before transporting or shipping back to NIICD.

See Transportation Instructions

!!!!!!WARNING!!!!
Never install batteries with the terminals facing each other!

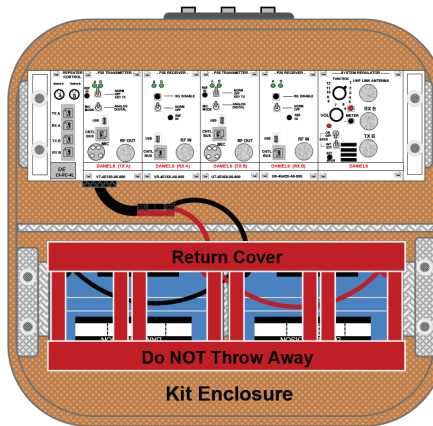
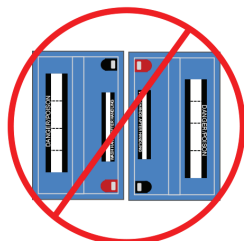

Equipment Kit Enclosure
12 Volt SLA Battery Configuration
With Battery Cover

APPENDIX B - 4330/4330EX SLA BATTERY INSTALLATION

All 4312, 4248, 4330, 4370 and 4248 kits will be sent from NIICD without any batteries physically connected to the equipment. The user must install the batteries from the NFES# 4150 SLA Battery Kit or NFES# 4080 Solar Panel Kit to make them operational. Please following the appropriate battery configuration and installation procedure for each piece of equipment.

1. 4150 SLA Kit Supplied Materials

- 1 each 4150 - SLA Battery Kit
- 2 each 35 AMP-HR SLA Battery
- 2 each Pre-Wired and connected Power-Pole Y-Cable

Note: Fused Battery Power-Pole adapter are included in each 4330 kit

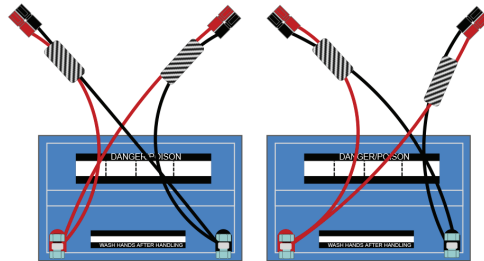

2. Configuring 4330 Radio Chassis Battery

- Ensure SLA battery is fully charged
- Place one SLA battery outside the chassis as shown
- Connect the SLA battery to chassis power input using the provided fused battery adapter
- Connect the fused battery adapter to the SLA Power-Pole battery cable as shown Red (+) and black (-)

*Note: Always remove the batteries from each kit before transporting or shipping back to NIICD.
See Transportation Instructions*

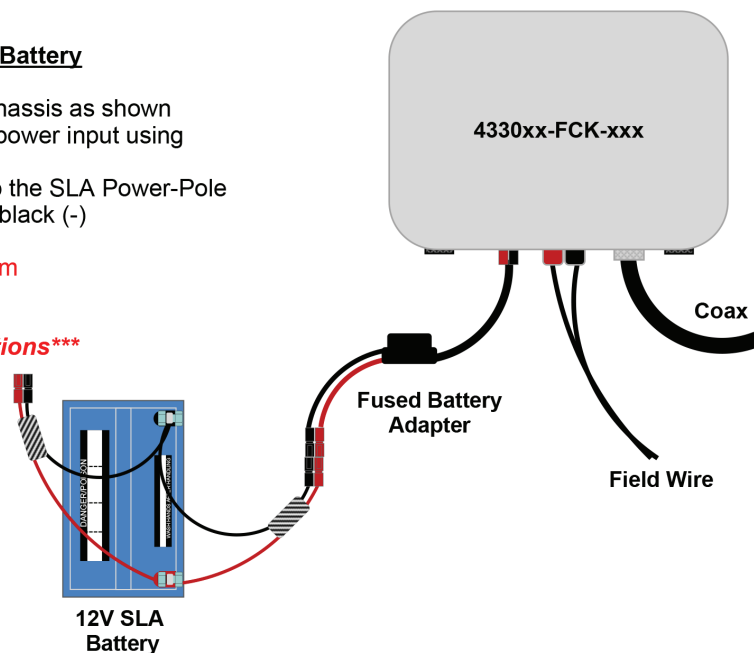

3. Configuring 4330 Handset Battery

- Ensure SLA battery is fully charged
- Place one SLA battery in close proximity to handset
- Connect the SLA battery to the handset power input using the provided fused battery adapter
- Connect the fused battery adapter to the SLA Power-Pole battery cable as shown Red (+) and black (-)

*Note: Always remove the batteries from each kit before transporting or shipping back to NIICD.
See Transportation Instructions*

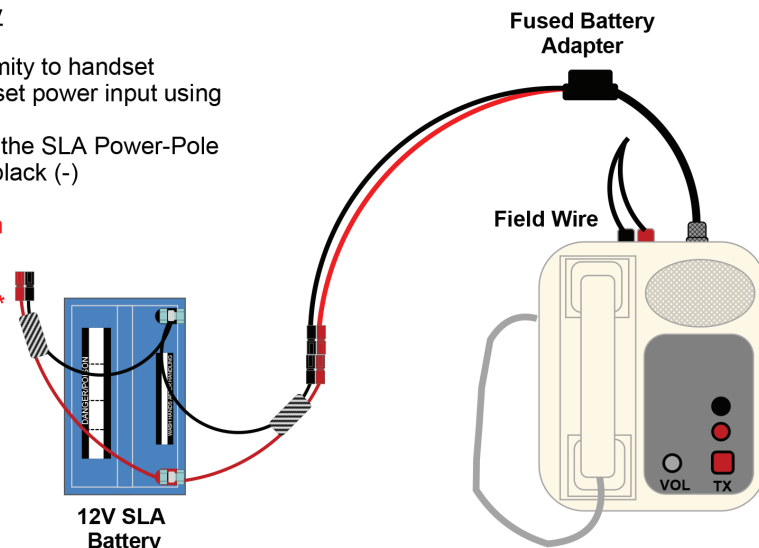

APPENDIX B - SLA BATTERY CHARGING AND WARNINGS

1. Battery Charger Configuration

- Plug A/C Plug on battery charger to electrical outlet
- Select "12V" using the upper "SELECT" button
- Select "AGM/FLOODED" using the lower "SELECT" Button

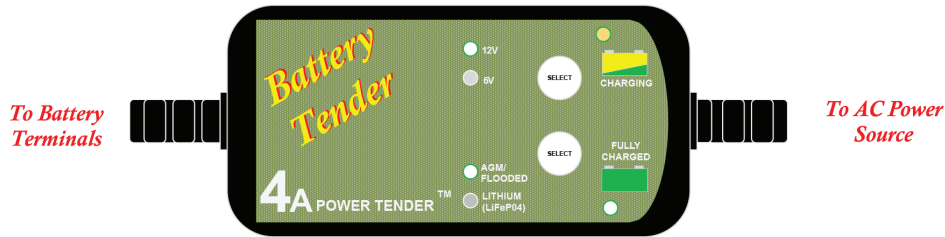

2. Battery Terminal Configuration

- Connect the provided Fused Cable Adapter to the SLA Battery
Note the Polarity, Red Clip (+) and Black Clip (-)
- A completely discharged battery will take about 10-hours to fully charge.
- Battery is charged when the charge indicator light is green

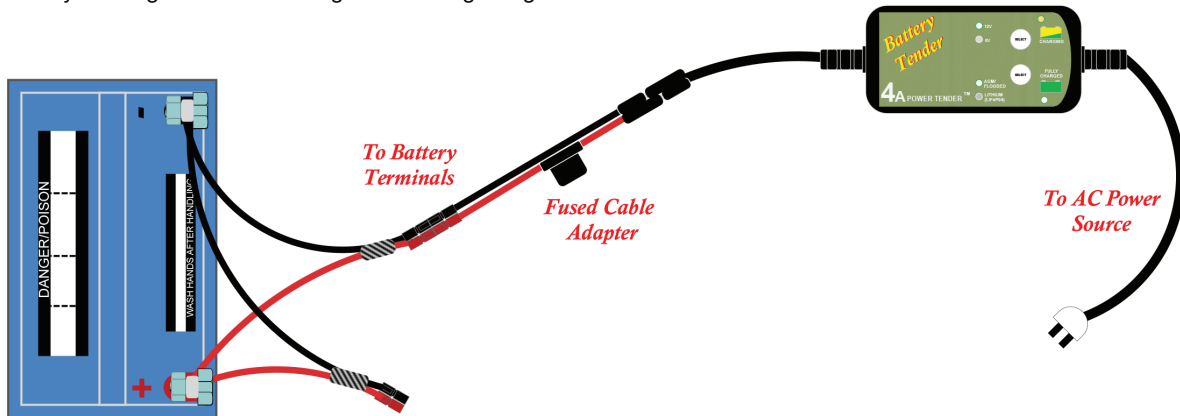

!!!NOTE!!!

Battery voltage must be greater than 3V for the battery charger to recognize the battery and begin charging.

SLA 4150 TRANSPORTATION INSTRUCTIONS

- Ensure battery terminals are covered during transportation.
 - If the plastic terminal covers are missing, cover the terminals with tape to prevent shorts.
- If spacer separating each battery is loose, secure batteries together with fiber tape to prevent movement and place the spacer to the side.
- Do not transport if 4150 pelican case foam is damaged or missing.
- Keep all foreign items out of the kit such as tools or stakes.

4150 SLA Battery Kit
Pelican Case Interior

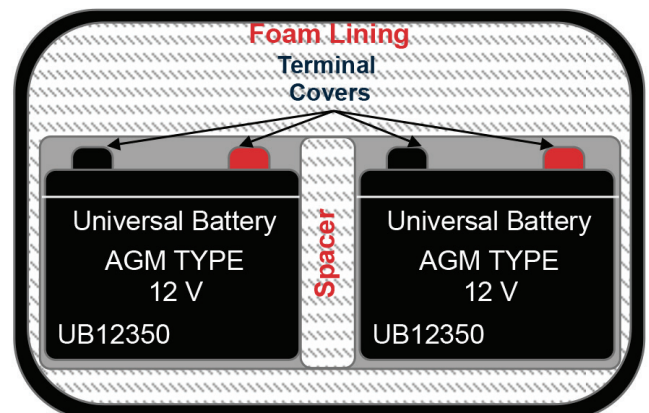

Note: Diagram does not show terminal wires or handles.

APPENDIX B - RADIO AND EQUIPMENT BATTERY MATRIX

BATTERY TYPES				
NFES#	000030	000033	004150	001241
VOLTAGES	1.5Volts (AA)	1.5Volts (D)	12Volts	9Volts
STANDARD CACHE PACKAGE	24/PG	12/PG	2/Kit	24/BX

HANDHELD RADIO CLAMSHELL BATTERY REQUIREMENTS					
RADIO TYPE	000030 (AA)	000033 (D)	001023 (7.5 V)	001241 (9 V)	Replacement Cycle
4381KD (KING DPH)	*9				**Every 12 Hours Max
4381K2 (KING KNG2)	*8				**Every 8 to 12 Hours Max
4381KR (KING BKR5000)	*12				**Every 8 to 12 Hours Max
4244X2 (MOTOROLA XTS)	*12				**Every 8 to 12 Hours Max
4244K2 (KING KNG2)	*8				**Every 8 to 12 Hours Max
4244MD (MIDLAND)	*6				**Every 8 to 12 Hours Max
ICOM IC-A6 (AM)	*6				**Every 12 Hours Max

* Note: Numbers reflect batteries required per clamshell.

** Note: Replacement Cycle is under ideal normal usage and is only a NIRSC recommendation.

Battery consumption is directly dependant on channel activity, channels scanned, priority mode, light operation, digital mode, and (PTT)Push-To-Talk cycles and duration.

EQUIPMENT KIT BATTERY REQUIREMENTS					
EQUIPMENT TYPE	000030 (AA)	000033 (D)	004150 (12 V)	001241 (9 V)	Replacement Cycle (Without Solar Panel Kits)
4248 - UHF REPEATER			*2		** Every 5 Days Max
4281 - CROSSBAND LINK			*2		** Every 5 Days Max
4312 - VHF REPEATER			*2		** Every 5 Days Max
4300 - AM BASE STATION	*40		*2		** Every 5 Days Max
4370 - GROUND A/C LINK	*40		*2		** Every 5 Days Max
4330 - REMOTE			*2		** Every 5 Days Max
4330EX - REMOTE EXPANSION			*2		** Every 5 Days Max

* Note: Numbers reflect batteries required per equipment kit .

** Note: Replacement Cycle is under heavy usage without solar kit and is only a NIRSC recommendation.

4390 STARTER SYSTEM BATTERY REQUIREMENTS		
SYSTEM TYPE	000030 (AA - 1.5 Volts)	004150 (12 Volts)
4390 w/DPH VHF/Motorola UHF Radios	*648 (27 Standard Packages)	**20 (5 Kits Included)
4390 w/DPH VHF /Midland UHF Radios	*552 (23 Standard Packages)	**20 (5 Kits Included)
4390 w/KNG VHF/KNG UHF Radios	*536 (23 Standard Packages)	**20 (5 Kits Included)
4390 w/KNG VHF/Midland UHF Radios	*600 (25 Standard Packages)	**20 (5 Kits Included)
4390 w/KNG VHF/Motorola UHF Radios	*504 (21 Standard Packages)	**20 (5 Kits Included)

* Note: AA Battery requirements are per Replacement Cycle of one (1) per shift.

** Note: 12 Volt Battery requirements are per Replacement Cycle of 5 days max without solar panel kit installed.